

SHURflo has supplied pumps to the RV industry for over 35 years. Our patented line of potable water pumps deliver smooth, consistent flow at all ranges of operation, while drawing low current. The balanced diaphragm design incorporates two precision ball bearings for long life. SHURflo pumps are 100% tested for proper operation before they leave the factory. When installed correctly, SHURflo water pumps will provide years of quiet operation.

A SHURflo pump in combination with a low backpressure water system can exceed all expectations. For unmatched reliability and trouble-free performance request SHURflo's complete line of water system products.

**Installation Guidelines**

- Solid surface.
- Accessible location away from living quarters.
- Properly sized wiring.
- Proper electrical protection.
- Flexible hose on inlet and outlet.
- Strainer on pump inlet.
- Minimize plumbing elbows and valves near the pump.
- Minimize flow restrictions in the system.

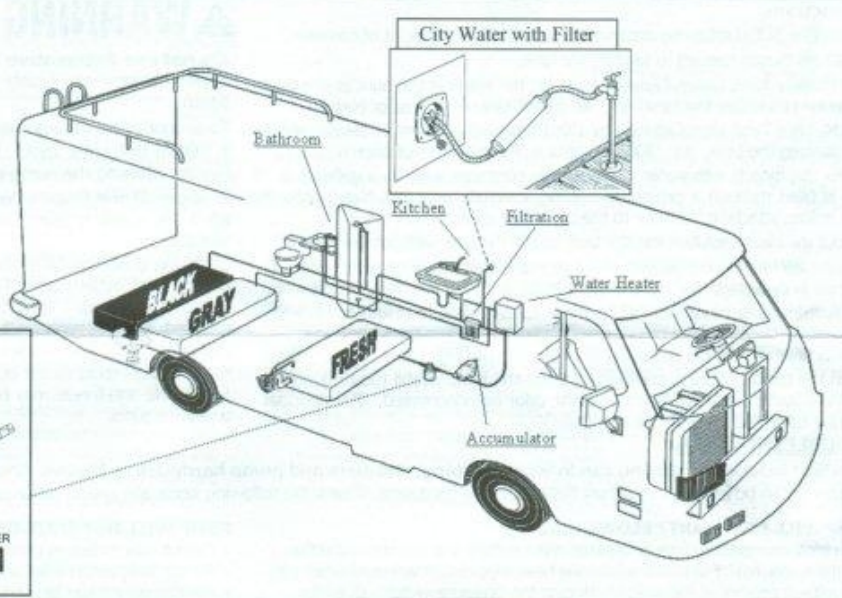
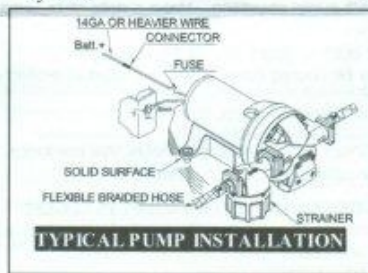

**GENERAL INFORMATION**

SHURflo realizes that in many instances our pump is being installed as a replacement pump within an existing system.

The following guidelines should be considered to achieve optimum pump operation. Always follow all local or national installation codes & standards.

**MOUNTING**

- The best mounting position is at the same level or below the water tank. It may be positioned above the water tank if needed, as it is capable of a 6 ft. [1.8M] vertical prime. Mount the pump within 6 feet total for best performance.
- Mount in a location that allows access for maintenance of the pump and strainer. The pump should be located in a ventilated space. Excessive heat may trigger the integral thermal breaker and interrupt operation. When the temperature drops the breaker will automatically reset and start operation.
- The pump may be mounted in any position.
- Choose a **solid** surface (thick plywood) that will not amplify pump operation. The mounting feet are intended to isolate the pump from the mounting surface; over-tightening, flattening, or use of oversized screws will reduce the ability to isolate vibration and noise through the lines.

**ELECTRICAL**

- The pump should be on a dedicated (individual) circuit, protected by the specified fuse or circuit breaker indicated on the motor label.
- Wire size (gauge/mm<sup>2</sup>) is based on the distance from the power source to the pump. Recommended size wire is #14 gauge [2.5mm<sup>2</sup>]. For lengths of 20-50ft. [6-15M] use #12 gauge [4 mm<sup>2</sup>].

**PLUMBING**

- SHURflo recommends at least 1ft. [3M] of ½" [13mm] I.D. flexible high-pressure tubing to both ports.
- The pumps ports/strainer **should not** be connected to plastic or rigid pipe. The pump's normal vibration may transmit through rigid plumbing causing noise, and possibly loosen or crack components.
- Installation of a 50-mesh strainer (SHURflo P/N 255) is required to prevent debris from entering the pump.
- Route tubing properly to eliminate hose kinking.

**OPERATION & SHUT-OFF ADJUSTMENT**

Pump cycling may be caused by excessive back pressure created by one or more of the following within a plumbing system:

- Low flow from partially open faucet.
- Water filters not on separate feed lines.
- Clogged water filters.
- Restrictive elbows, shut-off and check valves.
- Use as few elbows and valves as possible in the first two feet [.6M] after the pump.
- Flow restrictors in faucets and showerheads.
- Long lengths of small I.D. lines.
- Pipe/tubing should be at least ½" [13mm] I.D. for main lines.

- Restrictive fittings and connections (elbows "T"s, feeder lines to faucets, etc.) To minimize cycling, consider removing plumbing restrictions or simply install a SHURflo accumulator after the pump. Cycling should be minimized to prevent pulsating flow, and to achieve maximum pump life.

If the pump is cycling rapidly increase the setting by turning the screw clockwise (1½ turn MAX.) until the pump operates for 1 sec. with at least 2 sec. "OFF time".

**SCREW**



## SANITIZING

Potable water systems require periodic maintenance to keep components working properly and deliver a consistent flow of fresh water. Sanitizing is recommended prior to storing and before using the water system after a period of storage.

Systems with new components, or ones that have been subjected to contamination, should also be disinfected as follows:

**NOTE: Check your Vehicle Owner's Manual for specific instructions.**

1. Use one of the following methods to determine the amount of common household bleach needed to sanitize the tank.

A) Multiply Tank Gallon Capacity by 0.13; the result is the ounces of bleach needed to sanitize the tank. Ex: 80 gallon tank = 10.4 oz of bleach.

B) Multiply Tank Liter Capacity by 1.0; the result is the ml of bleach needed to sanitize the tank. Ex: 300 liter tank = 300 milliliters of bleach.

2. Mix the bleach with water in a pourable container such as a gallon jug. If tank is filled through a pressurized fitting, carefully pour the bleach into the hose before attaching the hose to the city water entry.

3. Pour the bleach solution into the tank and fill the tank with potable water.

4. Open **all** faucets (Hot&Cold) allowing the water to run until the odor of chlorine is detected. Now the system must sit to let the disinfectant work.

The system must have four (4) hours of contact time to disinfect completely. Doubling the solution concentration allows for a shorter contact time of one (1) hour.

When the contact time is completed, drain the tank. Refill the tank and flush the system once or twice until the odor has decreased. The residual chlorine odor and taste is not harmful.

## TROUBLESHOOTING

**Vibration induced by driving can loosen plumbing, strainers and pump hardware to loosen.** Check for system components that are loose. Many symptoms can be resolved by simply tightening the hardware. Check the following items along with other particulars of your system.

### PUMP WILL NOT START/ BLOWS CIRCUIT:

- ✓ Electrical connections, fuse or breaker, main switch, and ground connection.
- ✓ Is the motor hot? Thermal breaker may have triggered; it will reset when cool.
- ✓ Is voltage present at the switch? Bypass the pressure switch. Does the pump operate?
- ✓ Charging System for correct voltage ( $\pm 10\%$ ) and good ground.
- ✓ For an open or grounded circuit, or motor; or improperly sized wire.
- ✓ For seized or locked diaphragm assembly (water frozen?).

### WILL NOT PRIME/SPUTTERS: (No discharge/Motor runs)

- ✓ Is the strainer clogged with debris?
- ✓ Is there water in the tank, or has air collected in the hot water heater?
- ✓ Is the inlet tubing/plumbing sucking in air at plumbing connections (vacuum leak)?
- ✓ Is inlet/outlet plumbing severely restricted or kinked? Restrictive valves?
- ✓ Proper voltage with the pump operating ( $\pm 10\%$ ).
- ✓ For debris in pump inlet/outlet valves or swollen/dry valves.
- ✓ Pump housing for cracks or loose drive assembly screws.

### RAPID CYCLING:

- ✓ For restrictive plumbing and flow restrictions in faucets/shower heads.
- ✓ Water filter/purifier should be on separate feed line.

## SERVICE KITS

To insure the correct service kit, order by the complete pump model number, date of manufacture and other nameplate data. Part kits come with complete repair instructions. Pump illustrations may not be representative of all SHURflo potable water pumps and parts kits.

- 1 Switch, Check Valve and Upper Housing Kit
  - 2 Valve plate assembly
  - 3 Diaphragm / Drive assembly
  - 4 Motor
  - 5 Complete Pump Head assembly
- NS Check Valve Assembly

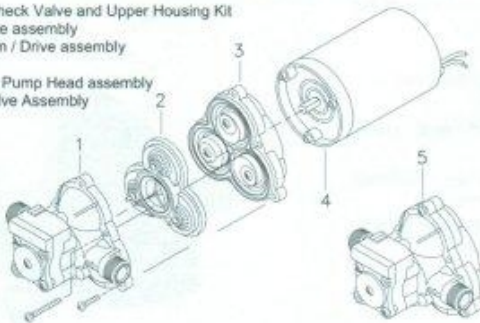

911-352 Rev. L 03/09 ECO 16260

## WINTERIZING

If water is allowed to freeze in the system, serious damage to plumbing and the pump may occur. Failures of this type will void the warranty. The best guarantee against damage is to completely drain the pump.

**NOTE:** When used per the manufacturers recommendations **non-toxic antifreeze for potable water** is safe for use with SHURflo pumps.

**Refer to the vehicle owner's manual for specific winterizing instructions.**

## WARNING

**Do not use Automotive Antifreeze** to winterize potable water system. Such solutions are highly toxic. Ingestion may cause serious injury or death.

To properly drain the pump perform the following:

1. Drain the water tank. If the tank doesn't have a drain valve, open faucets allowing the pump to operate until the tank is empty.
2. Open all the faucets (including the lowest valve or drain in the plumbing) allow the pump to purge the water from the plumbing, and then turn the pump OFF.
3. Using a pan to catch the remaining water, remove the plumbing at the pump's inlet/outlet ports. Turn the pump ON, allowing it to operate until the water is expelled. Turn OFF power to the pump once the plumbing is emptied. Do not reconnect plumbing. Make a note at tank filler as reminder: "Plumbing is disconnected".
4. All faucets must be left open to guard against any damage.
5. Potable anti-freeze may be poured down drains and toilet to protect p-traps and toilet seals.

### PUMP WILL NOT SHUT-OFF / RUNS WHEN FAUCET IS CLOSED:

- ✓ Output side (pressure) plumbing for leaks, and inspect for leaky valves or toilet
- ✓ For air trapped in outlet side (water heater) or pump head.
- ✓ For correct voltage to pump ( $\pm 10\%$ ).
- ✓ For loose drive assembly or pump head screws.
- ✓ Are the valves held open by debris or is the rubber swollen?
- ✓ Pressure switch operation.

### NOISY OR ROUGH OPERATION:

- ✓ For plumbing which may have vibrated loose.
- ✓ For a restricted inlet (clogged strainer, kinked hose, restrictive valves).
- ✓ Is the pump plumbed with rigid pipe causing noise to transmit?
- ✓ Does the mounting surface amplify noise (flexible)? Does it bang like a drum?
- ✓ For mounting feet that are loose or are compressed too tight.
- ✓ For air in the system. Check all fixtures for air and bleed system.
- ✓ The motor with pump head removed. Is noise from motor or pump head?

### LEAKS FROM PUMP HEAD OR SWITCH:

- ✓ For loose screws at switch or pump head.
- ✓ Switch diaphragm ruptured or pinched.
- ✓ For punctured diaphragm if water is present in the drive assembly.

## LIMITED WARRANTY

SHURflo warrants its aftermarket 2088 series potable water pumps to be free from material workmanship defects under normal use and service for 2 years (2093 = 3 years) from the date of purchase with purchase receipt or 2 years (2093 = 3 years) from the date of manufacture indicated on motor nameplate if no purchase receipt is available, as outlined in document MS-030-152. Pumps installed as original equipment fall under the warranty supplied by the manufacturer, as outlined in document 030-123.

The limited warranty will not apply to pumps that were improperly installed, misapplied, or incompatible with components not manufactured by SHURflo. Pump failure due to foreign debris is covered under the terms of this limited warranty. SHURflo will not warrant any pump that is physically damaged, or altered outside the SHURflo factory.

Warranty claims may be resolved by an authorized dealer service center, or by a SHURflo service center. Returns are to be shipped with charges pre-paid. Package all returns carefully. SHURflo will not be responsible for fire damage incurred during shipping to a service center.

For complete Limited Warranty details, consult SHURflo.

SHURflo reserves the right to update specifications, prices, or make substitutions.



SHURflo, LLC Headquarters  
6960 Kellen Avenue  
Cypress, California 90630  
Phone (562) 795-5200 • Toll Free (800) 854-3218  
Fax (562) 795-7954

SHURflo, LLC East  
30748 Park St Court  
Elkhart, Indiana 46514-0427  
Phone (562) 795-5200 • Toll Free (800) 854-3218  
Fax (574) 264-2168

SHURflo Europe, Middle East, & Pacific  
Pentair Water Belgium NV/SA  
Industrieweg 10/11a, Tolksmattlaan 3  
B-2200 Herentals, Belgium  
Phone +32-14-283500 • Fax +32-14-281

© 2008 SHURflo, LLC. All Rights Reserved.

2 of 2