



INSTALLATION AND OPERATION MANUAL

SHURflo's Marine Duty Fresh Water Pumps were developed to endure the harsh marine environment. The patented design delivers smooth, consistent flow at all ranges of operation, while drawing low current. The balanced motor design incorporates precision ball bearings for long life, motor is equipped with an integral thermal breaker and U/L Marine listed. All Marine duty pumps have sealed switches and are finished with a Electro Coating to inhibit corrosion. Marine duty fresh water pumps are enclosed to prevent incidental moisture from entering and when installed correctly, Marine Duty Fresh Water Pumps provide years of quiet operation.

GENERAL INFORMATION

SHURflo realizes that in many instances our pump is being installed as a replacement pump within an existing system. The following guides should be considered to achieve optimum pump operation.

Mounting

- The pump can be at the same level or below the water tank. It may be positioned above the water tank if needed, as it is capable of a 6 ft. [1.8M] vertical prime. Horizontal inlet tubing will allow priming to 30 ft. [9 M].
- Consider a *dry* location that allows easy access if maintenance is required. The pump should not be located in an area of less than one cubic foot unless adequate ventilation is provided. Excessive heat may trigger the integral thermal breaker and interrupt operation. When the temperature drops the breaker will automatically reset and start operation. The pump can be mounted in any position. If mounting the pump vertically, the pump head should be in the down position.

TYPICAL INSTALLATION

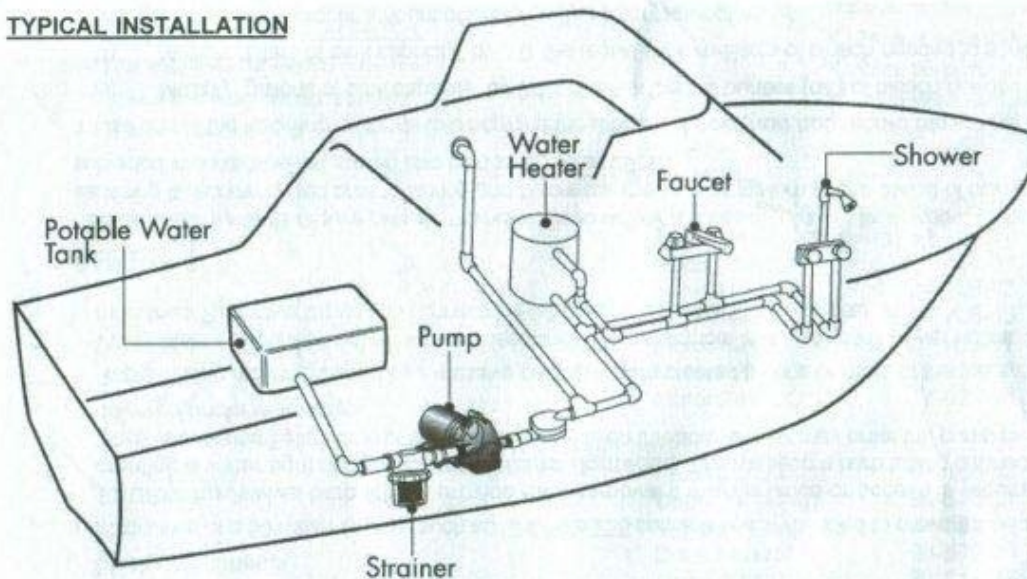

Electrical

- The pump should be on a dedicated (individual) circuit protected by the specified fuse indicated on the motor label.
- A U/L approved marine duty (ignition protected) switch rated at or above 15 amps is recommended and must interrupt current flow on the positive (+ red) lead.
- The pump must be grounded to a "known ground" (battery). The ground wire must be the same size (gauge/mm²) as the positive wire.
- Wire size (gauge/mm²) is based on the distance from the power source to the pump. Recommended size wire is #14 gauge [2.5mm²]. For lengths of 20-50ft. [6-15M] use #12 gauge [4 Mm²].
- The total current draw on the circuit **must not** exceed 15 amps. If the pump is used in conjunction with other components, overload current protection (fuse or circuit breaker) and wire size must be for the total amp requirement of all devices on the circuit.

PLUMBING:

- SHURflo recommends at least 1ft [.3M] of ½"[13mm] I.D. flexible high pressure tubing to both ports. Ideally the pump's ports/strainer **should not** be connected to plastic or rigid pipe. The pump's normal oscillation may transmit through rigid plumbing causing noise, and possibly loosen or crack components.
- Installation of a 50 mesh strainer such as SHURflo 255 series is recommended to prevent foreign debris from entering the pump.
SHURflo hex/swivel barb fittings provide easy removal if maintenance or access is required. The fittings are designed with a "taper-seal", creating a water tight connection when **hand-tightened**. Always secure barb tubing connections with properly sized stainless steel clamps to prevent leaks. **Never** use Teflon tape or sealing compounds on threads. Sealer may enter the pump causing a failure. **Failure due to foreign debris is not covered under warranty.**
- Rapid cycling may be caused by excessive back pressure created by one or more of the following within a plumbing system:
Water filters and purifiers not on separate feed lines, Flow restrictors in faucets and shower heads, Small ID lines Pipe/tubing should be at least 1/2" [13mm] for main lines, Restrictive fittings and connections (elbows, "T"s, feeder lines to faucets, etc).

SANITIZING:

Potable water systems require periodic maintenance to deliver a consistent flow of fresh water. Depending on use and the environment the system is subject to, sanitizing is recommended prior to storing and before using the water system after a period of storage. Systems with new components, or ones that have been subjected to contamination, should also be disinfected as follows:

1. Use one of the following methods to determine the amount of **common household bleach** needed to sanitize the tank.
 - A) Multiply "gallons of tank capacity" by 0.13; the result is the ounces (oz.) of bleach needed to sanitize the tank.
 - B) Multiply "Liters of tank capacity" by 1.0; the result is the milliliters of bleach needed to sanitize the tank.
2. Mix into solution the proper amount of bleach within a container of water.
3. Pour the solution (water/bleach) into the tank and fill the tank with potable water.
4. Open **all** faucets (HOT&COLD) allowing the water to run until the distinct odor of chlorine is detected.

WINTERIZING:

If water is allowed to freeze in the system, serious damage to the plumbing and the pump may occur. Failures of this type will void the warranty. The best guarantee against damage is to completely drain the water system.

NOTE:

When used per the manufacturers recommendations **non-toxic antifreeze for potable water** is safe for use with SHURflo pumps. Refer to the manufacturer for their specific winterizing & drainage instructions.

CAUTION: Do not use Automotive Antifreeze to winterize potable water systems. Such solutions are highly toxic. Ingestion may cause serious injury or death.

To properly drain the system perform the following:

1. Drain the water tank. If the tank doesn't have a drain valve, open all faucets allowing the pump to operate (15 min. ON / 15 min. OFF) until the tank is empty.
2. Open all the faucets (including the lowest valve or drain in the plumbing) and allow the pump to purge the water from the plumbing, then turn the pump OFF.
3. Using a pan to catch the remaining water, remove the plumbing at the pump's inlet/outlet ports. Turn the pump ON, allowing it to operate until the water is expelled. Turn OFF power to the pump once the plumbing is emptied. **Do not** reconnect pump plumbing. Make a note at tank filler as a reminder. "Plumbing is Disconnected".
4. All faucets must be left open to guard against any damage.

TROUBLESHOOTING

Vibration induced by sea conditions or transporting can cause plumbing or pump hardware to loosen. Check for system components that are loose. Many symptoms can be resolved by simply tightening the hardware. Check the following items along with other particulars of your system.

PUMP WILL NOT START/ BLOWS CIRCUIT:

- ✓ Is the motor hot? Thermal breaker may have triggered, it will reset when cool.
- ✓ Electrical connections, fuse or breaker, main switch, and ground connection.
- ✓ Is voltage present at the switch?
- ✓ Charging System for correct voltage ($\pm 10\%$) and good ground.
- ✓ For an open or grounded circuit, or motor, or improperly sized wire.
- ✓ For seized or locked diaphragm assembly (water frozen?).

WILL NOT PRIME/SPUTTERS: (No discharge/Motor runs)

- ✓ Is the strainer clogged with debris?
- ✓ Is there water in the tank, or has air collected in the hot water heater?
- ✓ Is the inlet tubing/plumbing sucking in air at plumbing connections (vacuum leak)?
- ✓ Is inlet/outlet plumbing severely restricted or kinked?
- ✓ Proper voltage with the pump operating ($\pm 10\%$).
- ✓ For debris in pump inlet/outlet valves or swollen/dry valves.
- ✓ Pump housing for cracks or loose drive assembly screws.

LEAKS FROM PUMP HEAD OR SWITCH:

- ✓ For loose screws at switch or pump head.
- ✓ Switch diaphragm ruptured or pinched.
- ✓ For punctured diaphragm if water is present in the drive assembly.

PUMP WILL NOT SHUT-OFF / RUNS WHEN FAUCET IS CLOSED:

- ✓ Output side (pressure) plumbing for leaks, and inspect for leaky valves or toilet.
- ✓ For air trapped in outlet side (water heater) or pump head.
- ✓ For correct voltage to pump ($\pm 10\%$).
- ✓ For loose drive assembly or pump head screws.
- ✓ Are the valves or internal check valve held open by debris or is rubber swollen?
- ✓ Pressure switch operation/adjustment incorrect, refer to shut-off adjustment for switch.

NOISY OR ROUGH OPERATION:

- ✓ For plumbing which may have vibrated loose.
- ✓ Is the pump plumbed with rigid pipe causing noise to transmit?
- ✓ Does the mounting surface multiply noise (flexible)?
- ✓ For mounting feet that are loose or are compressed too tight.
- ✓ For loose pump head to motor screws. (3 long screws)
- ✓ The motor with pump head removed. Is noise from motor or pump head?

RAPID CYCLING:

- ✓ Pressure switch shut-off adjustment.
- ✓ Water filter/purifier should be on separate feed line.
- ✓ For restrictive plumbing, flow restrictors in faucets/shower heads.

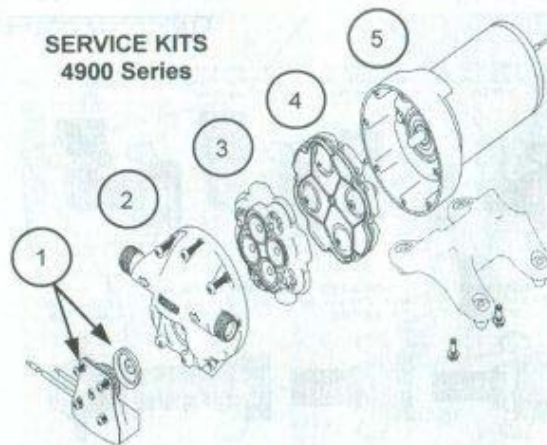

SERVICE KITS
4900 Series

290X/390X Series

1	Pressure Switch	94-706-00
1	Pressure Switch (290X)	94-706-07
2	Upper Housing	94-706-01
3	Valve Housing	94-706-02
4	Drive Assembly	94-706-06
5	Motor 12V DC (290X)	77-035-17
5	Motor 12V DC	77-023-17
5	Motor 24V DC	77-029-17

4900 Series

1	Pressure Switch	94-668-00
2	Upper Housing	94-670-01
3	Valve Housing	94-669-00
4	Drive Assembly	94-670-00
5	Motor 12V DC	77-013-07

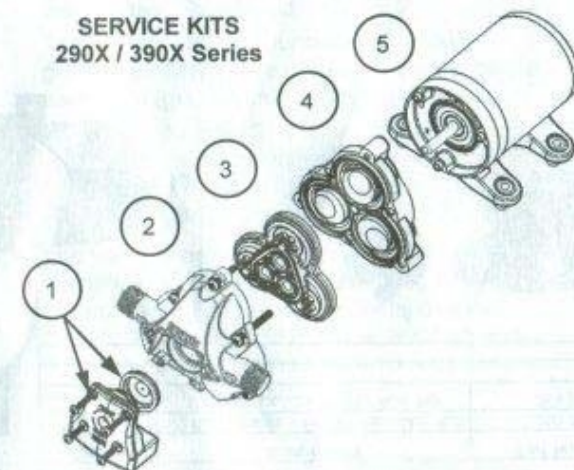

SERVICE KITS
290X / 390X Series

HEX-WING FITTINGS AVAILABLE

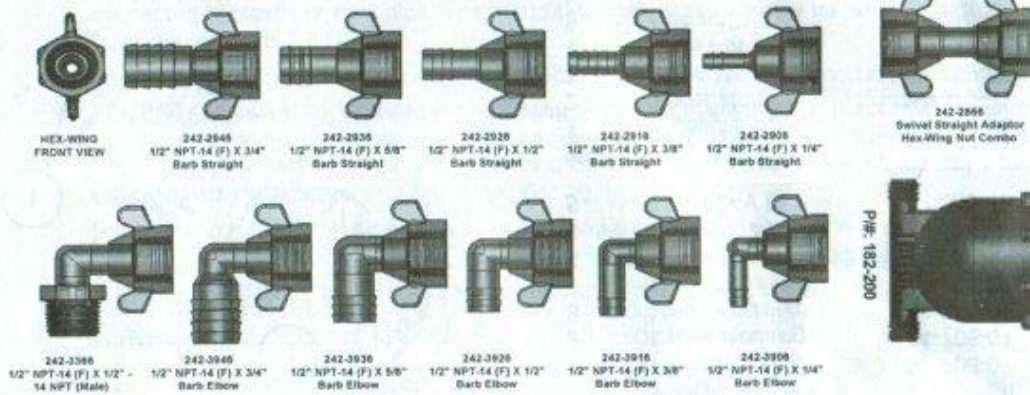

STRAINERS AVAILABLE:

Number	Components	Part Number
1	1/2 Barb Straight x 1/2 NPT Hex Wing Nut	255-225
2	1/2 NPS-M x 1/2 NPT Hex Wing Nut	255-215



LIMITED WARRANTY

SHURflo warrants its Marine Duty Fresh Water Pumps to be free from material and workmanship defects under normal use and service for a period of three (3) years from the date of purchase. In the absence of proof of purchase the warranty is three (3) years from the date of manufacture indicated on the motor nameplate, not to exceed (3) three years in any event. The limited warranty will not apply to pumps that were improperly installed, misapplied, or are incompatible with components not manufactured by SHURflo. Pump failure due to foreign debris is not covered under the terms of this limited warranty. SHURflo will not warrant any pump that is physically damaged, or altered outside the SHURflo factory. Warranty claims may be resolved by an authorized dealer service center, or by a SHURflo service center. Returns are to be shipped with charges pre-paid. Package all returns carefully. SHURflo will not be responsible for freight damage incurred during shipping to a service center. SHURflo's obligation under this warranty policy is limited to the repair or replacement of the pump. Pumps found not defective (under the terms of this limited warranty) are subject to charges to be paid by the returnee for the testing and packaging of "tested good" units. Warranty returns will be shipped on a freight allowed basis. SHURflo reserves the right to choose the method of transportation. SHURflo is not responsible nor will it reimburse for labor necessary to remove and reinstall a pump, if found defective. This warranty is only a representation of the complete Marine Products Limited Warranty outlined by Service Bulletin # 1050.



Fare riferimento al sito www.shurflo.com per manuali multilingue di installazione ed utilizzo prodotti.



Favor de referirse a www.shurflo.com para instrucciones de la instalación del producto y su operación, disponible en varios idiomas.



Veillez vous référer au site www.shurflo.com pour l'installation produit multilingue ainsi que pour le mode d'emploi.



Mehrsprachige Hinweise zu Installation und Betrieb des Produktes finden Sie unter www.shurflo.com



Please refer to www.shurflo.com for multi-lingual product installation and operating instructions!

SHURflo reserves the right to update specifications, prices, or make substitutions.



SHURflo, LLC Headquarters
 5900 Katella Avenue
 Cypress, California 90630
 Phone (562) 795-5200 • Toll Free (800) 854-3218
 Fax (562) 795-7584

SHURflo, LLC East
 52748 Park Six Court
 Elkhart, Indiana 46514-5427
 Phone (562) 795-5200 • Toll Free (800) 854-3218
 Fax (574) 264-2169

SHURflo Europe, Middle East, Africa
Pentair Water Belgium bvba,
 Industriepark Wolfstee, Toekomstlaan 30
 B-2200 Herentals, Belgium
 Phone +32-14-283500 • Fax +32-14-283505

Visit Caravans Plus – <http://www.caravansplus.com.au/>